

FOR HIGHER DISCHARGE HEADS

ELMRIDGE 'TLLT Series' Liqui-Jet Eductors use water or other liquids as the motive fluid, and operate on the Venturi principle to pump other liquids or slurries. The principle of operation for the TLLT Series is the same as for the TLL Series shown previously, however, the TLLT Series eductor has higher Motive Nozzle flowrates for the same Motive Pressure, providing for higher Discharge heads with somewhat lower Suction Flowrates. This is typically appropriate when diluting strong acids or bases, and in dosing chemicals in smaller ratios where somewhat higher discharge pressures may be required. Operating characteristics (Water Motive / Water Suction), for standard models are shown below, and special units are also available to meet your specifications. Standard materials of construction are PVC, CPVC, Polypropylene, PVDF, Bronze/Brass, Cast Iron/Steel, 316L Stainless Steel, Alloy 20, and Hastelloy C®. Other materials are available upon request. Threaded, flanged, sanitary, butt weld, or socket weld connections (except Cast Iron).

Table TLLT-1 Suction Capacity (usgpm water) for a TLLT5 Liqui-Jet Eductor using 70 deg. F Water

Suction Lift (feet water)	Discharge Head (feet water)	Operating Water Pressure (psig)							
		10	20	30	40	50	60	80	100
0	0	16.9	19.6	19.6	19.6	19.6	19.6	19.6	19.6
	20	-	9.9	18.6	19.6	19.6	19.6	19.6	19.6
	40	-	-	-	11.5	19.1	19.4	19.5	19.6
	60	-	-	-	-	6.7	14.0	19.5	19.6
	80	-	-	-	-	-	-	15.8	19.6
	100	-	-	-	-	-	-	4.6	18.0
5	0	12.4	18.3	18.6	18.6	18.6	18.6	18.6	18.6
	20	-	5.4	16.1	17.3	17.6	17.8	18.3	18.6
	40	-	-	-	9.7	17.4	17.6	18.2	18.6
	60	-	-	-	-	4.8	12.4	18.1	18.6
	80	-	-	-	-	-	-	14.5	18.6
	100	-	-	-	-	-	-	-	16.8
10	0	8.1	15.0	15.3	15.4	16.1	16.4	16.9	17.6
	20	-	-	14.0	15.4	15.7	16.2	16.8	17.6
	40	-	-	-	8.2	15.6	16.0	16.7	17.6
	60	-	-	-	-	-	11.0	16.6	17.6
	80	-	-	-	-	-	-	14.0	17.6
	100	-	-	-	-	-	-	-	15.9
15	0	-	12.6	12.9	13.4	14.1	14.3	15.4	16.1
	20	-	-	11.5	13.4	13.9	14.4	15.3	16.1
	40	-	-	-	6.2	13.8	14.2	15.2	16.1
	60	-	-	-	-	-	9.9	15.1	16.1
	80	-	-	-	-	-	-	12.9	16.1
	100	-	-	-	-	-	-	-	15.0
20	0	-	9.8	10.8	11.4	12.2	13.0	14.0	15.2
	20	-	-	9.1	11.4	12.2	12.9	14.0	15.2
	40	-	-	-	-	11.9	12.8	13.8	15.2
	60	-	-	-	-	-	8.6	13.7	15.2
	80	-	-	-	-	-	-	11.8	15.2
	100	-	-	-	-	-	-	-	15.2
25	0	-	7.8	8.8	10.1	10.9	11.5	13.0	14.8
	20	-	-	7.0	10.0	10.7	11.5	13.0	14.8
	40	-	-	-	-	10.1	11.5	12.9	14.8
	60	-	-	-	-	-	7.6	12.8	14.8
	80	-	-	-	-	-	-	11.0	14.8
	100	-	-	-	-	-	-	-	14.8
Power Water Consumption (USGPM)		25.2	35.6	43.7	50.4	56.4	61.6	71.2	79.6



**SEE INDIVIDUAL
DIMENSIONAL
DRAWINGS BY
STYLE**

Table TLLT-2 Capacity Factors

Model	TLLT00	TLLT0	TLLT1	TLLT2	TLLT3	TLLT4	TLLT5	TLLT6	TLLT7	TLLT8	TLLT9	TLLT10	TLLT11	TLLT12	TLLT13	TLLT14	TLLT15	TLLT16
Capacity Factor	0.027	0.050	0.091	0.165	0.30	0.55	1.00	1.80	3.24	4.30	5.71	7.57	10.1	13.3	17.7	23.5	31.2	41.4

PUMPING LIQUIDS

APPLICATION EXAMPLES

EXAMPLE 1:

It is required that a resin slurry (S.G. = 1.2), be pumped from a barrel at the rate of 2.6 USGPM. The maximum suction lift is 5 feet and the maximum discharge head is 60 feet. Water is available at 80 psig pressure for operating the eductor.

- From Table TLLT-1, the TLLT5 eductor has a suction capacity of 18.1 USGPM of water under the conditions given. Suction flowrate of the resin slurry is:

$$18.1 \times \text{SQRT} (1 / 1.2) = 16.5 \text{ USGPM}$$

- The required Capacity Factor is:

$$2.6 / 16.5 = 0.158$$

- From the Capacity Factor Table TLLT-2, the Capacity Factor of the TLLT2 Eductor is 0.165, ie. the suction capacity of the TLLT2 at the given operating conditions is:

$$0.165 \times 16.5 = 2.72 \text{ USGPM}$$

The capacity can be reduced, if necessary, by throttling the power water supply.

- Power Water Consumption of the TLLT2 at 80 p.s.i.g. is:

$$71.2 \times 0.165 = 11.75 \text{ USGPM}$$

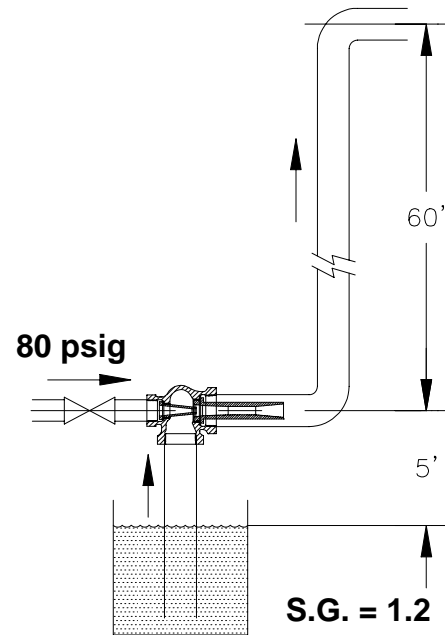

EXAMPLE 2:

It is required that a brine solution (S.G. = 1.11), be pumped from a tank in a specific ratio to the power water (1:5 [Vol.] brine to water). Total mixture flowrate required is 35 USGPM. The maximum suction lift is 4.5 feet and the maximum discharge head is 58 feet. Water is available at 60 psig pressure for operating the eductor.

- The actual suction lift corrected for the Specific Gravity of the brine solution is:

$$4.5 \times 1.11 = 5.0 \text{ feet of water}$$

- The brine flowrate (Suction Flow) required is:

$$35 / (1 + 5) = 5.8 \text{ USGPM}$$

- Power Water flowrate is therefore:

$$35 - 5.8 = 29.2 \text{ USGPM}$$

- From Table TLLT-1, the TLLT5 eductor has a Power Water flowrate of 61.6 USGPM and a suction capacity of 12.4 USGPM under these conditions.

- The required Capacity Factor is:

$$29.2 / 61.6 = 0.47$$

- From the Capacity Factor Table TLLT-2, the Capacity Factor of the TLLT4 eductor is 0.55, ie. the suction capacity of the TLLT4 at the given operating conditions is:

$$0.55 \times 12.4 = 6.82 \text{ USGPM}$$

